

Parts List

Big Bench Top (x1)
Bench Supports - Outside (x4)
Bench Supports - Inside (x2)
14g x 75 mm Bugle Screws (x8)
14g x 50 mm Bugle Screws (x12)



Instructions

Step 1 Place bench top face down on a flat surface.

Step 2 Place centre supports (x2) over the blocks on the middle bearer. Take note as to which side the pre-drilled holes are located. Fix in 6 x 50 mm bugle screws per support.

Step 3 Place outside supports (x4) into position. Once in position, align the pre-drilled holes and fix with 75 mm bugle screws supplied.

Step 4 Once all screws have been tightened, turn the bench over and place into position.

Diagram

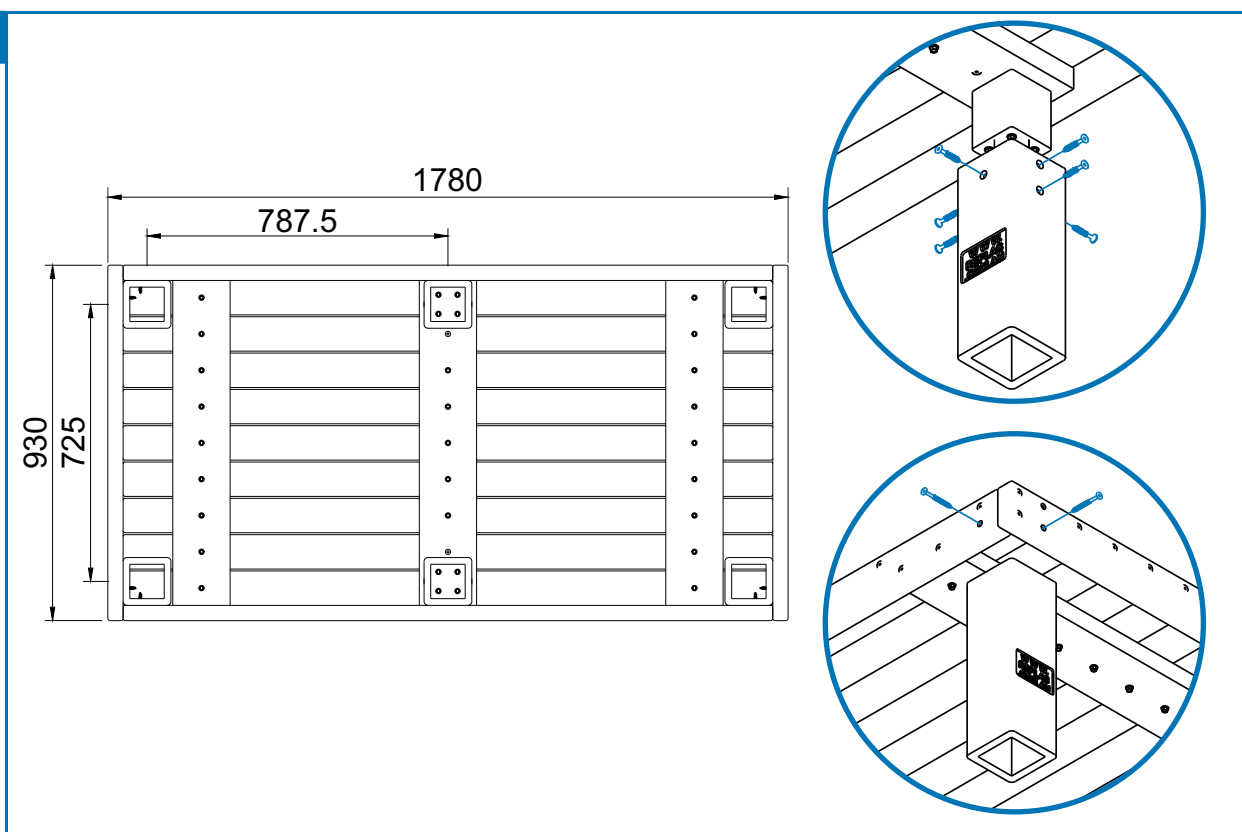

All dimensions are in millimetres (mm) unless specified.

If you require further assistance, please contact your supplier.

Rev: 3