

## ASSEMBLY INSTRUCTIONS

**IMPORTANT: Please read carefully before assembling.**

# PREMIER SETTING

1.8m In Ground  
Wheel Chair Access



1. Place Table & Bench tops face down on a flat surface.
2. Place supports inside metal frame.
3. Using a 3.5mm drill bit, drill into the support through the pilot holes in the metal frame.
4. Using the 40mm Hex screws supplied, screw support onto frame.

### **Installation**

Once the setting has been assembled, drill or dig holes as per installation diagram.

Place the supports of the assembled setting into the holes. Position the setting and ensure that it is well braced to prevent movement and sagging. At this stage it is important to use a spirit level to check that the top is horizontal and the supports are vertical.

Once satisfied that the setting is positioned correctly, fill the holes with concrete, making sure it is packed firmly around the supports.

Once the concrete has set, remove the bracing.

### **SUGGESTION:**

When installing In-Ground furniture it is a good idea to nail some timber bracing across the back of all supports. This will ensure all supports are kept parallel and in alignment, as well as preventing any sagging of the seat during installation. Do not remove bracing until after concrete has set.

## **COMPONENTS LIST**

### TABLE:

- 1 X Table Top - pre-assembled
- 2 X Table Supports
- 16 X 12g x 40mm Hex Screws

### BENCHES:

- 2 X Bench Tops - pre-assembled
- 4 X Bench Supports
- 24 X 12g x 40mm Hex Screws

If you require further installation assistance, please contact your supplier.

SIDE VIEW - Table only

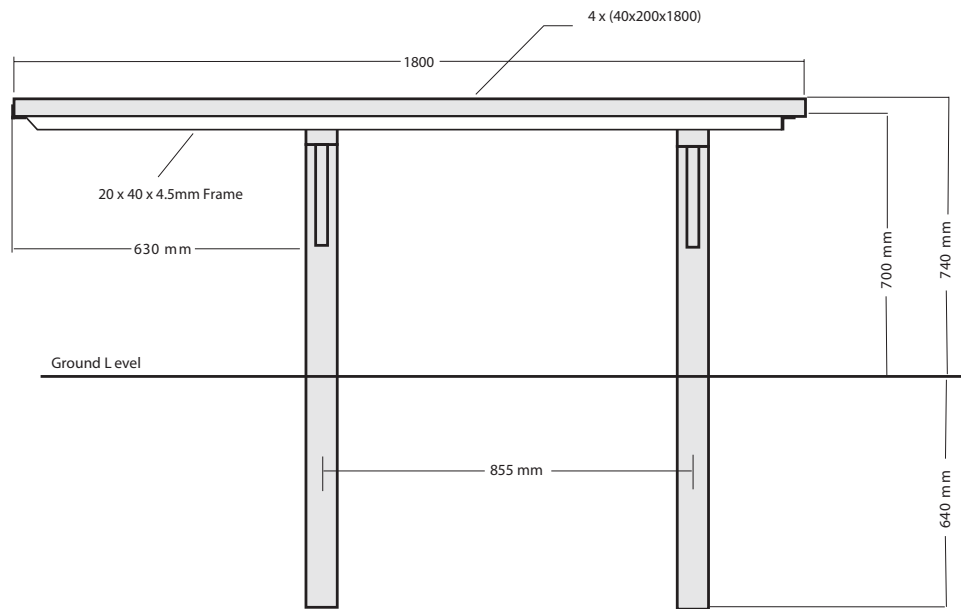

SIDE VIEW - Bench only

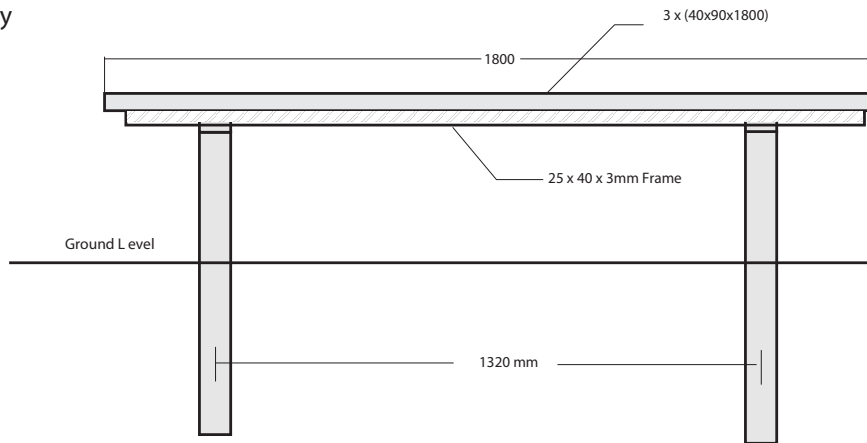

END VIEW

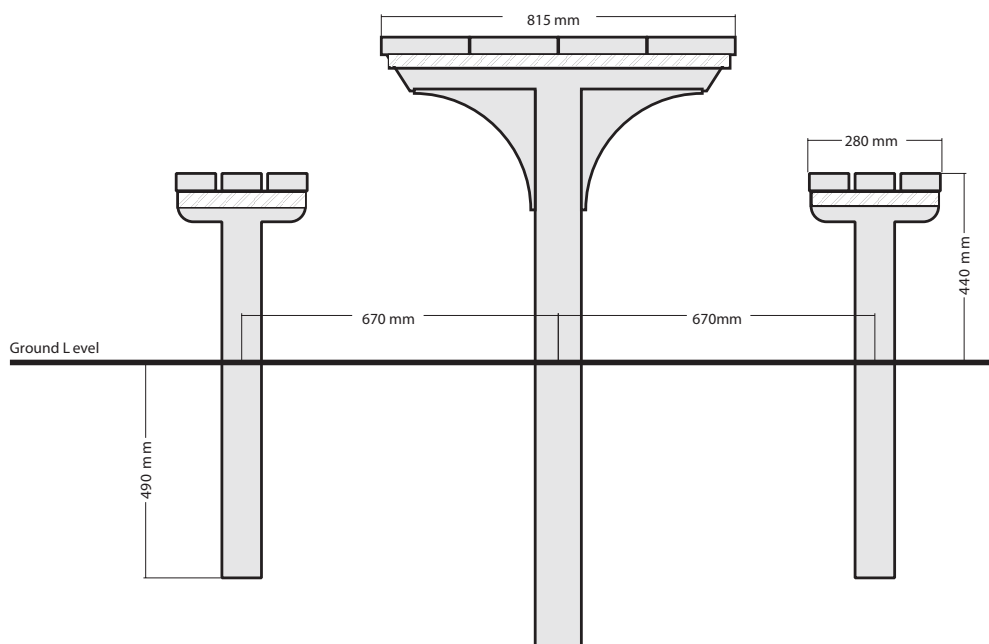

PRS-1800IG/WCA  
PREMIER  
IN GROUND  
SETTING WITH  
WHEELCHAIR ACCESS