



ASSEMBLY INSTRUCTIONS

IMPORTANT: Please read carefully before assembling.

PREMIER SETTING

1.8m Free Standing
Wheel Chair Access



1. Place Table & Bench tops face down on a flat surface.
2. Place supports inside metal frame.
NOTE: Ensure that the Table Supports have the counter sink holes facing outwards on the support upright
3. Using the 75mm bugle screws supplied, fit crossarm between the two table supports.
4. Using a 3.5mm drill bit, drill into the support through the pilot holes in the metal frame.
5. Using the 40mm Hex Screws supplied, screw support onto frame, taking care not to over tighten as this could strip the thread in the support.
6. Once all screws have been tightened, turn setting over and place into position

COMPONENTS LIST

TABLE:

1 X Table Top - pre-assembled
2 X Table Supports
1 X Table Crossarm - 805mm
4 X 14g x 75mm Bugle screws
16 X 12g x 40mm Hex Screws

BENCHES:

2 X Bench Tops - pre-assembled
4 X Bench Supports
24 X 12g x 40mm Hex Screws

If you require further installation assistance, please contact your supplier.

www.replas.com.au

SIDE VIEW - Table only

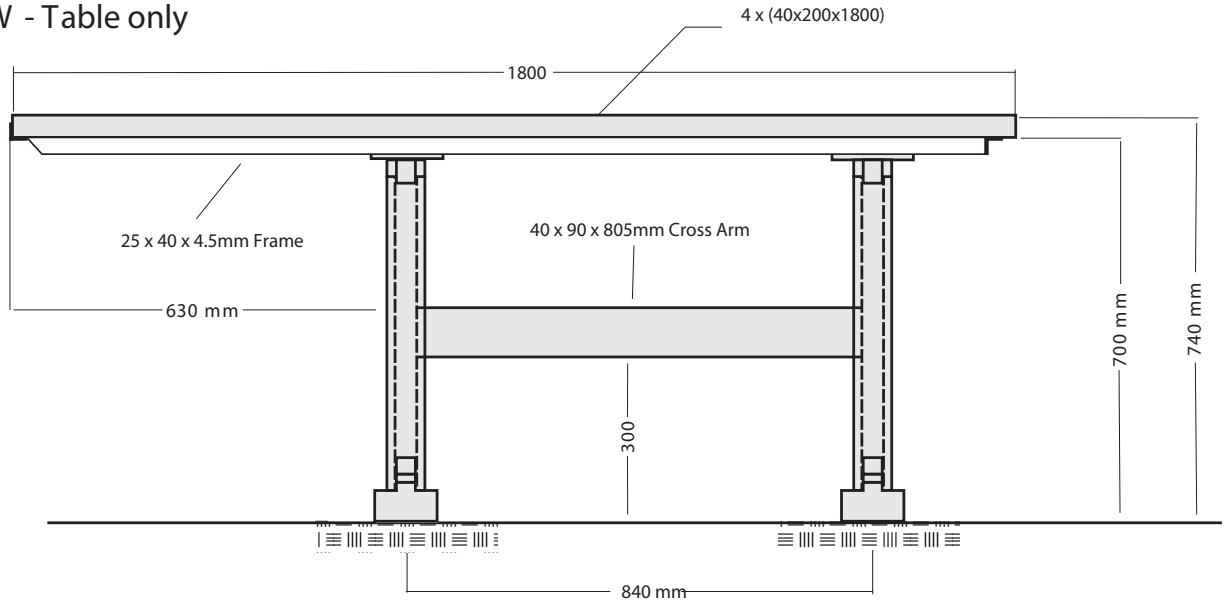

SIDE VIEW - Bench only

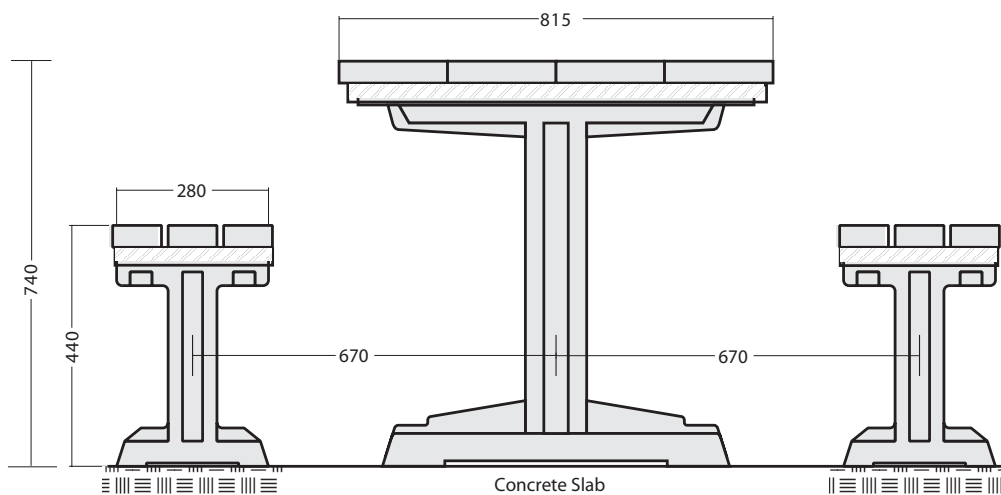
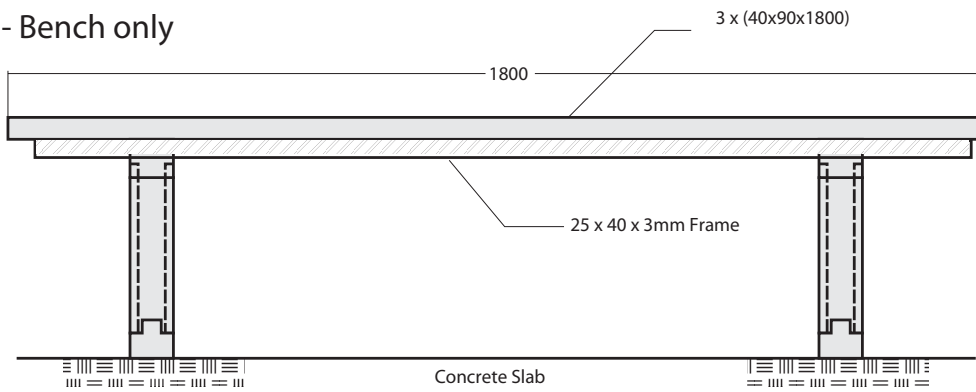

PRS-1800FS/WCA
PREMIER
FREE STANDING
SETTING WITH
WHEELCHAIR ACCESS